

Heat meters Cooling meters

AMR systems

Compact meters

Splitt meters

Energy calculators

Flow sensors

Accessories



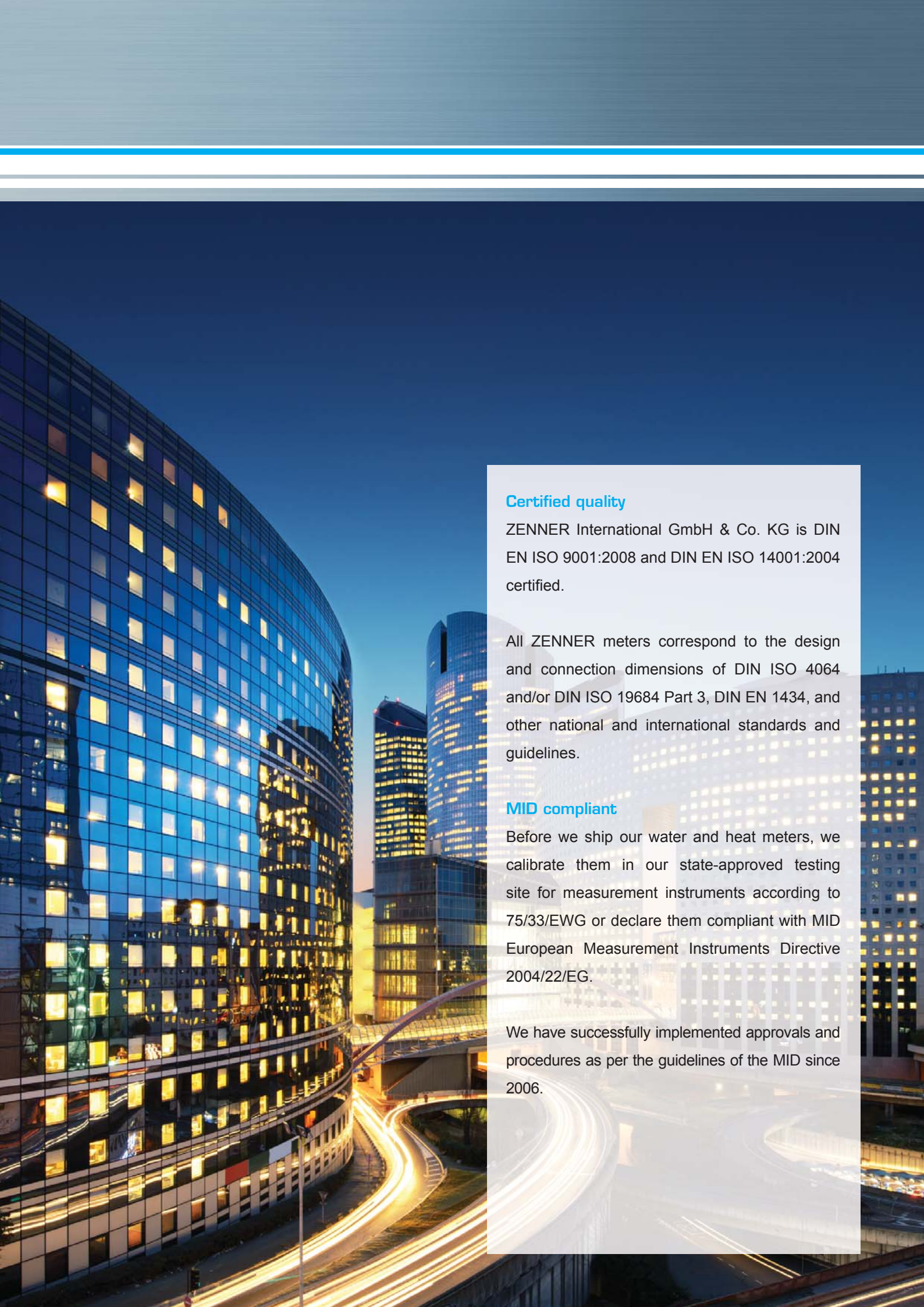

Certified quality

ZENNER International GmbH & Co. KG is DIN EN ISO 9001:2008 and DIN EN ISO 14001:2004 certified.

All ZENNER meters correspond to the design and connection dimensions of DIN ISO 4064 and/or DIN ISO 19684 Part 3, DIN EN 1434, and other national and international standards and guidelines.

MID compliant

Before we ship our water and heat meters, we calibrate them in our state-approved testing site for measurement instruments according to 75/33/EWG or declare them compliant with MID European Measurement Instruments Directive 2004/22/EG.

We have successfully implemented approvals and procedures as per the guidelines of the MID since 2006.

Heat meters / cooling meters

Heat and cooling meters to measure energy consumption

Customers around the world have relied on our experience and the quality and reliability of our products for more than 100 years. We sell more than 300.000 heat and cooling meters each year, which places us among the leading providers of innovative measurement technology on all five continents.

We have the right products and custom solutions for all technological requirements available, in particular for our customers in the housing industry, in district heating or district cooling industry.

These include compact and split-meters as well as modern ultrasonic meters and appropriate remote reading technologies.

Technology derived from experience

The technology in our products reflects our experience of over 100 years of development and production. We are constantly pushing the functionality of our meters forward in our on-going development process. This enables us to offer our customers products that will be functional for years to come.

AMR-Technologies

ZENNER meters are not only accurate, but can also be easily integrated into a variety of smart metering systems. The ZENNER systems technology offers modular solutions for individual customer requirements.

The portfolio includes wired bus systems and wireless radio solutions as well as related software solutions for programming and reading of the systems.



Heat meter components

Temperature sensor, flow sensor, energy calculator

A heat meter always consists of three components – a flow sensor, a pair of temperature sensors and an energy calculator. The quantity of water flowing through the heating circuit is recorded by a flow sensor. ZENNER employs flow measurement solutions tailored to the specific measuring activity, from a single-jet flow sensor to ultrasonic technology.

The temperature sensor detects the difference in temperature between the heating system's flow and return, required to calculate the heat quantity. ZENNER uses various designs of high-precision platinum resistance temperature sensor for this purpose.

The energy calculator calculates the quantity of heat consumed using the temperature and volume information and the associated heat coefficient (K factor).

The energy calculator also displays current values for heat output, flow rate, flow and return temperatures and temperature difference.



Compact meters

Compact heat meters combine the three components of energy calculator, temperature sensor and flow sensor as a fixed whole. The equipment is calibrated as a unit and must be entirely replaced in case of meter replacement. This type of equipment offers maximum value for money with a low design height.

ZENNER uses the term 'Combi' to describe compact heat meters where the energy calculator can be detached from the flow sensor but is inseparably connected to it via a cable. Combi equipment is for example used if the installation site has limited space and the energy calculator does not fit or is difficult to read on the flow sensor.



Split heat meters

Split heat meters are meters where all three components (energy calculator, flow sensor and temperature sensor) can be individually calibrated and/or checked for conformity and can be independently assembled into a heat meter by the user. The individual components can be replaced separately.

Split equipment is extremely flexible and can be assembled from an energy calculator and various different combinations of flow sensors and temperature sensors. This enables it to adapt to all forms of measurement.



ZENNER AMR systems

For individual requirements

As varied and individual as the needs of our customers on a remote reading system, as diverse and individual are our solutions and products that we develop for different customer groups worldwide.



Bus systems

M-Bus and ZR-Bus

Wired remote readout system for requesting meter data in large buildings and properties. Developed for the housing industry, energy suppliers and industry.



Download the ZENNER
AMR-catalog on www.zenner.com





Wireless M-Bus



Walk-by radio system OPERA

Walk-by radio system for remote meter reading. Specially developed for water and energy supply companies.



Stationary GSM system

Meter reading via GSM and internet

System for remote meter reading and monitoring of measuring points via GSM and internet with data transfer via SMS and online meter administration.



zelsius® C5 series

New generation of electronic compact heat and cooling meters

The new zelsius® C5 combines efficiency with compact construction, maximum precision and most advanced communication interfaces for M-Bus and wireless M-Bus. The zelsius® C5 is available in three different versions with a single-jet (ISF), ultrasonic (IUF) or measuring capsule (CMF) flow sensor. Reliability and large dynamic range ensure optimal measurement results.

Specially designed for consumption-based energy billing, zelsius® C5 is well prepared for use in all real estate with central heat supply:

- industrial and business buildings
- apartment buildings and residential complexes
- multi-family buildings

In addition to measuring heating energy consumption, the zelsius® C5 can also be used as a meter in cooling systems or in combined heating/cooling systems.

The advantages of zelsius® C5 are evident even during installation. With its compact design zelsius® adapts easily to nearly any installation situation. Models with an ultrasonic and measuring capsule flow sensor allow for the energy calculator to be removed as standard and mounted up to 1.2 meters away.

This is a huge benefit in areas with limited space such as distribution boxes or transmission stations. This function is also available as an option for the single-jet flow sensor model. The Combi version with removable calculator allows installation even in the smallest distribution boxes.

The operating concept for the zelsius® CF series energy calculator with generous LC display is the same regardless of the flow sensor technology used. This makes work significantly easier for reading staff and significantly reduces the risk of reading errors.



YouTube

The zelsius® C5 has various interfaces for smart remote reading of meter data. These include an M-bus interface in accordance with DIN EN 13757 with unlimited selection frequency, a radio interface for wireless M-bus in accordance with OMS (Open Metering System) specifications and three programmable pulse inputs or outputs also for use with M-bus or radio.

A combined optical data interface (ZVEI and IrDA) for reading and programming is available as standard.

Characteristics in a glance

- Available as heating/cooling meter or in Combi version for heating/cooling
- Very low design height
- Optionally available with M-bus or wireless M-bus
- Optionally available with 3 inputs / outputs
- Optionally available with temperature measurement cycle of 4 seconds
- Any mounting position (including overhead for IUF model)
- Storage of all monthly values throughout its service life
- Optionally available with 11-year battery life (depending on country)
- Precise, long-term stability
- Wide dynamic range
- MID-compliant in either class 2 or 3 depending on flow sensor



zelsius® C5 CMF
with measuring capsule flow sensor



zelsius® C5 ISF
with single-jet flow sensor



zelsius® C5 IUF
with ultrasonic flow sensor

zelsius® C5 CMF

Heat and cooling meter with measuring capsule flow sensor



The new zelsius® C5 CMF with coaxial measuring capsule combines compactness with rugged construction.

The zelsius® C5 CMF energy calculator is detachable, and with a cable length of 1.2 metres also enables installation in cramped areas.

With reaction-free electronic impeller detection, the zelsius® C5 CMF meets the current metrological requirements for compact heat meters and due to its measuring capsule is an excellent replacement meter for connection interfaces in accordance with DIN EN ISO 4064.

Options for exchanging existing meters

Typ Ista
IST, G2"



C5 CMF IST

Typ Techem
TE1, M62x2



C5 CMF TE1

Typ Sensus
PCC, M60x2



C5 CMF PCC

Typ Minol
M60, M60x1,5



C5 CMF M60

Typ Allmess
A1, M77x1,5



C5 CMF A1

Technical data flow sensor CMF				
Nominal flow q_p	m ³ /h	0,6	1,5	2,5
Maximum flow q_s	m ³ /h	1,2	3	5
Minimum flow q_i horizontally*	l / h	24	30 / 60	50 / 100
Minimum flow q_i vertically*	l / h	24	30 / 60	50 / 100
Starting flow horizontally ca.	l/h	5	5	7
Pressure loss at q_p	bar	< 0,25 bar		
Temperature range	°C	10°C ≤ θ_q ≤ 90°C		
Minimum pressure (to avoid cavitation)	bar	0,3		
Measurement accuracy class		3		
Connection interface*		M60, IST, TE1, A1, PCC		
Nominal pressure	PS/PN	16		
Nominal diameter	DN	depending on the connecting interface		
Installation position		horizontally or vertically		
Installation		return flow optionally forward flow		
Cable length up to calculator (in combi version)	m	1,2		
Installation place temperature sensors		M10 x 1		
Heat transfer medium		water		

*optionally

Technical data temperature sensors			
Platinum resistance		Pt 1000	
Sensor diameter/type*	mm	PSC 45x5,2; PSC 45x5,0; DS 6; DS 27,5	
Temperature range	°C	0 - 105	
Cable length	m	1,5 (opt. 5)	
Installation	FF	by direct immersion or by immersion sleeves (in case of existing measuring points)	
	RF	by direct immersion or by immersion sleeves (in case of existing measuring points); optionally integrated in flow sensor	

*optionally

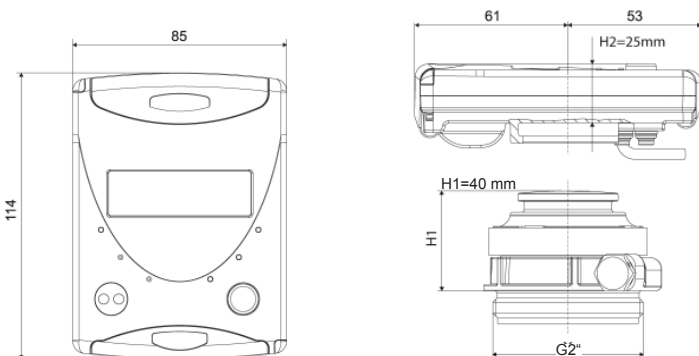

Technical data calculator		
Temperature range	°C	0...105
Temperature difference range	K	3...80
Display		LCD 8-digit + additional character
Ambient temperature	°C	5...55
Minimum temperature difference	K	3
Resolution temperature	°C	0,01
Measurement frequency (adjustable ex works)	s	Standard 30 M-bus interface 10 Special version 2
Unit to read the heat consumption		Standard MWh; optionally kWh, GJ
Data backup		once a day
Due date values		Storage of all monthly values during the entire operating time
Maximum value storage		extensive storage of flow rate, performance and other parameters
Interface	Standard	optical interface (ZVEI, IrDA)
	optional	M-bus, wM-bus
Supply		3,6 V lithium battery (different capacities)
Battery lifetime	years	> 6, opt. > 11 (changeable during the operating time)*
Protection class		IP54**
EMC		C
Ambient conditions / climatic influencing (valid for complete compact meter)	- climatic	Highest permissible ambient temperature 55°C Lowest permissible ambient temperature 5°C Humidity class IP54
	- mechanical class	M1
	- elektromagnetic class	E1

** IP65 for flow sensor of combi version heat-/cooling meter

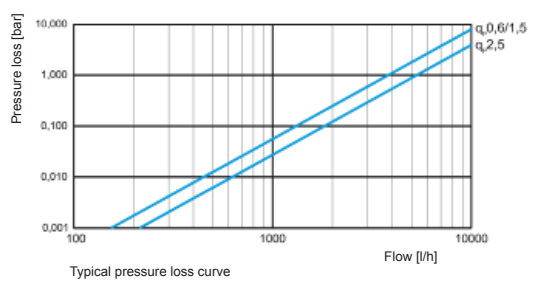

zelsius® C5 ISF

Heat and cooling meter with single-jet flow sensor



Zelsius® compact heat meters boast innovative measuring technology with state-of-the-art scanning electronics to record even small consumption amounts.

The zelsius® C5 ISF is a threaded meter, equipped with a rugged single-jet flow sensor (ISF) with reaction-free electronic impeller detection, simple to replace and available in all common sizes.

zelsius® C5 ISF for water-glycol heat carriers

In addition, the zelsius® C5 is also available for water-glycol-mixtures, e.g. to use in heat pumps and solar systems. As a special feature, it provides the ability to program the type of glycol (propylene or ethylene glycol), and the water mixture ratio directly from the meter and to change it again if necessary.

The meter therefore offers considerable logistical benefits as programming no longer has to be completed in the factory. With 14 programmable water-glycol mixtures, the zelsius® C5 ISF thus covers a total of 15 heat carriers.

Dimensions

Nominal flow	q_p	m^3/h	0,6	1,5	2,5
Nominal diameter	DN	mm	15	15	20
Installation length	L	mm	110	110	130
Height	H1	mm	40	40	40
Required mounting space min. = 30 mm					

Dimensions

Compact version	H_{max}	= 55 mm
	E_{max}	= 21 mm
Combi version (H1+H2)	H_{max}	= 65 mm
	E_{max}	= 21 mm

Technical data flow sensor ISF				
Nominal flow q_p	m ³ /h	0,6	1,5	2,5
Maximum flow q_s	m ³ /h	1,2	3	5
Minimum flow q_i horizontally*	l / h	12 / 24	30 / 60	50 / 100
Minimum flow q_i vertically*	l / h	12 / 24	30 / 60	50 / 100
Starting flow horizontally ca.	l/h	4	4	5
Pressure loss at q_p	bar	< 0,25 bar		
Temperature range	°C	10°C ≤ θ_q ≤ 90°C		
Minimum pressure (to avoid cavitation)	bar	0,3		
Measurement accuracy class		3		
Nominal pressure	PS/PN	16		
Nominal diameter	DN	15	15	20
Installation length	mm	110	110	130
Installation position		horizontally or vertically		
Installation		return flow optionally forward flow		
Cable length up to calculator (in version combi)	m	1,2		
Installation place temperature sensors		M10 x 1		
heat transfer medium		water (water-glycol without approval)		

*optionally

Technical data temperature sensors				
Platinum resistance		Pt 1000		
Sensor diameter/type*	mm	PSC 45x5,2; PSC 45x5,0; DS 6; DS 27,5		
Temperature range	°C	0 - 105		
Cable length	m	1,5 (opt. 5)		
Installation	FF	by direct immersion or by immersion sleeves (in case of existing measuring points)		
	RF	by direct immersion or by immersion sleeves (in case of existing measuring points); optionally integrated in flow sensor		

*optionally

Technical data calculator		
Temperature range	°C	0...105
Temperature difference range	K	3...80
Display		LCD 8-digit + additional character
Ambient temperature	°C	5...55
Minimum temperature difference	K	3
Resolution temperature	°C	0,01
Measurement frequency (adjustable ex works)	s	Standard 30 M-bus interface 10 Special version 2
Unit to read the heat consumption		Standard MWh; optionally kWh, GJ
Data backup		once a day
Due date values		Storage of all monthly values during the entire operating time
Maximum value storage		extensive storage of flow rate, performance and other parameters
Interface	Standard	optical interface (ZVEI, IrDA)
	optional	M-bus, wM-bus
Supply		3,6 V lithium battery (different capacities)
Battery lifetime	years	> 6, opt. > 11 (changeable during the operating time)*
Protection class		IP54**
EMC		C
Ambient conditions / climatic influencing (valid for complete compact meter)	- climatic	Highest permissible ambient temperature 55°C Lowest permissible ambient temperature 5°C Humidity class IP54
	- mechanical class	M1
	- electromagnetic class	E1

** IP65 for flow sensor of combi version heat-/cooling meter

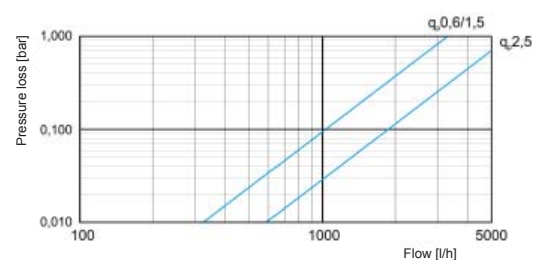
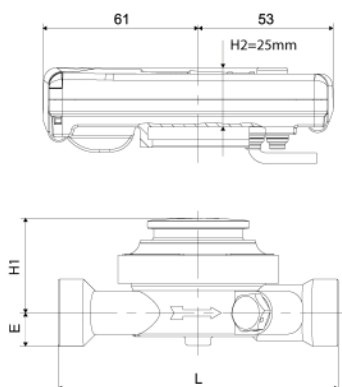
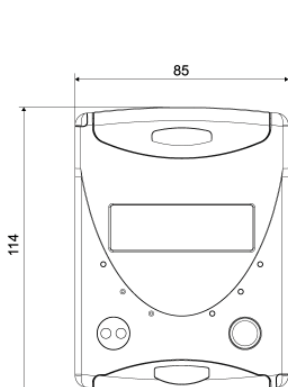

Typical pressure loss curve

zelsius® C5 IUF

Heat and cooling meter with ultrasonic flow sensor



The zelsius® C5 IUF ultrasonic heat and cooling meter uses an innovative ultrasonic technology, specially developed for domestic energy and district heating measurement.

Thanks to a combination of modern measuring technology and a very compact design, the zelsius® C5 IUF is outstandingly suitable for recording all accounting data for measuring energy consumption in heating and/or cooling plants. The wear-free ultrasonic technology is dirt-resistant, stable over the long term and also reliable for very low volume flow rates.

Ultrasonic flow sensors can be used continuously up to a heat medium temperature of 130°C and are ideal for use in district heating supply. Thanks to their high overload capacity and wear-free measuring technology, they can also be used to measure energy in hot water supply systems in accordance with section 9 (2) of the German Heating Costs Ordinance.



Technical data flow sensor IUF						
Nominal flow q_p	m ³ /h	0,6	1,5	2,5		
Maximum flow q_s	m ³ /h	1,2	3	5		
Minimum flow q_i^*	l / h	6 / 12 / 24	15 / 30 / 60	25 / 50 / 100		
Pressure loss at q_p	bar	< 0,25 bar				
Temperature range of the heat transfer medium*	°C	0°C ≤ θ_q ≤ 90°C / 105°C 0°C ≤ θ_q ≤ 130°C				
Minimum pressure (to avoid cavitation)	bar	1 at q_p and 80 °C temperature of the heat transfer medium				
Measurement accuracy class		3 / 2				
Nominal pressure	PS/PN	housing with threaded connection	16/16			
Maximum pressure	PS/PN	housing with flange connection	25/25			
Protection class		IP 68				
Installation position		any position				
Installation		return flow, optionally forward flow				
Cable length up to calculator (in version combi)	m	1,2				
Installation place temperature sensors		M10 x 1				
Heat transfer medium		Water				
Nominal diameter	DN	15	15	20		
Connection sizes	Nominal diameter q_p [m ³ /h]	L [mm]	threaded connection	Flange / DN		
			0,6	110	G¾B	--
			0,6	130	G1B	--
			0,6	190	G1B	20
			1,5	110	G¾B	--
			1,5	130	G1B	--
			1,5	190	G1B	20
2,5	130	G1B	--			
2,5	190	G1B	20			

*optionally

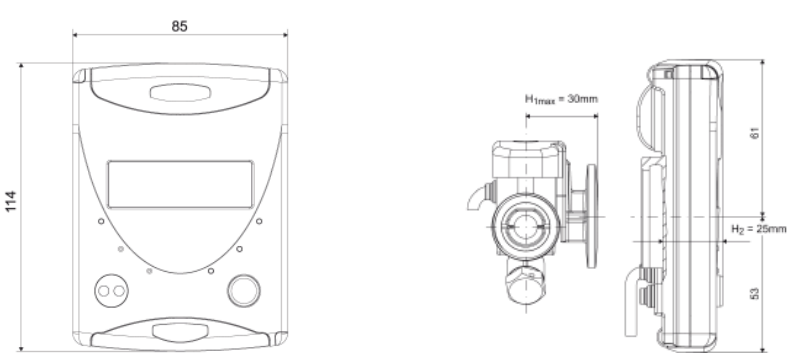

Technical data calculator		
Temperature range	°C	0...105 / 0...150
Temperature difference range	K	3...80 / 3...130
Display		LCD 8-digit + additional character
Ambient temperature	°C	5...55
Minimum temperature difference	K	3
Resolution temperature	°C	0,01
Measurement frequency (adjustable ex works)	s	Version with temperature sensors up to 105°C: Standard: 32 M-bus-interface: 8 Special version: 4 Version with temperature sensors up to 150°C: Standard: 4
Unit to read the heat consumption		Standard MWh; optionally kWh, GJ
Data backup		once a day
Due date values		Storage of all monthly values during the entire operating time
Maximum value storage		extensive storage of flow rate, performance and other parameters
Interface	Standard	optical interface (ZVEI, IrDA)
	optional	M-Bus, wM-Bus
Supply		3,6 V lithium battery (different capacities)
Battery lifetime	years	> 6, opt. > 11 (changeable during the operating time)*
Protection class		IP54**
EMC		C
	- climatic	Highest permissible ambient temperature 55°C Lowest permissible ambient temperature 5°C Humidity class IP54
	- mechanical class	M1
Ambient conditions / climatic influencing (valid for complete compact meter)	- elektromagnetic class	E1

** IP65 for flow sensor of combi version heat-/cooling meter

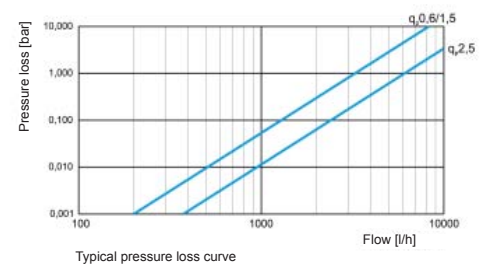

Split-energy-meters

Heat and cooling meters to measure energy consumption



ZENNER offers a comprehensive range of split heat and cooling meters for larger volume flows.

Split devices are extremely flexible and can be combined with the matching calculators, static or mechanical flow sensors and temperature sensors in order to meet individual requirements.



Specifically configured multidata WR3 calculators are used in combination with mechanical or ultrasonic flow sensors. A wide range of temperature sensor variants, several immersion sleeves and the necessary installation accessories round off the range.

ZENNER provides individual solutions in each measuring task for:

- Heat meters
- Cooling energy meters with national German approval (PTB TR K 7.2)
- Combined heat/cooling meters (Change-over)

The corresponding components are approved according to the specific measuring task. Split equipment energy calculators are available with various interfaces and can be integrated into M-bus systems or (via external modules) into radio systems or a GSM system.

Flow sensors

Flow sensors are measuring equipment specially designed for high temperatures that is used in heating circuits. Mechanical flow sensors transfer pulses via a reed contact, a process which is compatible with all ZENNER and other standard energy calculators. The bearing is particularly robust thanks to a hardened metal and sapphire construction. All mechanical flow sensors are dry running, protecting the counter from high temperatures. The particular construction and the material design ensure long-term measurement stability and excellent reliability. All mechanical flow sensors are

designed for temperatures of up to 120°C with temporary capacity for up to 130°C.

Single-jet flow sensors are very compact devices which can be used for flows of up to q_p 2.5. They can be mounted horizontally or vertically.

Multi-jet flow sensors are particularly suitable for horizontal installation positions with medium flow rates of q_p 3.5 bis q_p 10. In vertical pipelines, the advantage of special standpipe/downpipe housing is that the counter is in a horizontal position despite the vertical pipe. This means significantly greater long-term stability for measuring results as load is taken off the bearings.

From a nominal diameter of DN 50, q_p 15 or upwards, Woltman flow sensors are used, which feature very low starting flows combined with high measuring accuracy and outstanding measuring stability even with extreme loads. Ultrasonic flow sensors are available as alternatives for all the nominal flows indicated.



Energy calculator multidata WR3

Energy calculator for heat and cooling meters

The multidata WR3 split energy calculator can be combined with all common flow sensors and temperature sensors.

Easy installation

The multidata WR3 can be opened up without tools. The calibration area is on the casing cover, meaning that the casing base can remain in position during connection work.

Any malfunctions are automatically identified and shown in the display with a corresponding code. Non-volatile memory safely stores all relevant data at regular intervals. The energy calculator is also optionally available with a freely programmable data logger.

Suitable for heating and cooling

In a special version with certification under the PTB TR K 7.2 standard, the multidata WR3 can also be used in cooling systems and enables legally compliant billing and distribution of cooling energy. The multidata WR3 is also ideally suited to the combined measurement of heating and cooling energy. The consumption values measured for cooling and heating are stored in separate registries. It is deployed in air-conditioning units where the same pipe network is used to supply heating and cooling energy.

Easy operation

The multifunction display permanently shows the current consumption value. On the split energy calculator, all relevant measuring data can be accessed in three self-explanatory display loops by pressing the operating key. This also includes instantaneous values (heat output, temperatures, heat medium flow rate) for a plausibility check.



286.04 MWh

2200.00 m³

3.58 °C

40.367 m³/h

Excellent compatibility

The truly multi-talented multidata WR3 works with almost all flow sensor sizes. A special version is available for flow sensors with a high-frequency pulse output.

In addition to the flow sensor, all equipment offers the ability to connect two further devices via the pulser, e.g. a cold and a hot water meter. Meter readings can be accessed via the device menu or using read-out systems.

Characteristics in a glance

- As a heating, cooling or combined heating/cooling energy calculator
- Two additional inputs/outputs as standard
- Body can be opened without tools
- Optionally available with M-Bus, RS 232 or RS 485 interface
- Wall and rail mounting included
- Also available as a version with an external mains adaptor

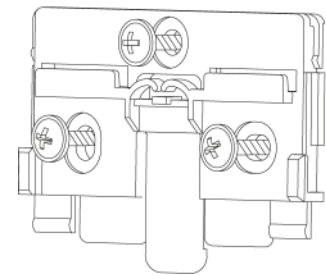
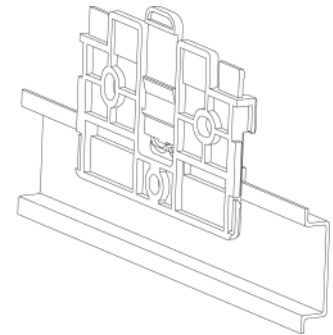

Technical data multidata WR3			
Temperature range		°C	0 - 150
Temperature difference range		k	3 - 120
Temperature sensors			PT 100 / 500 / 1000
Battery lifetime		years	6 / 11
Protection class		IP	54, 65
Interface			optical, M-Bus
Depth	T	mm	54
Height	H	mm	106
Wide	B	mm	120
Mechanical class			M1
Electromagnetic class			E1

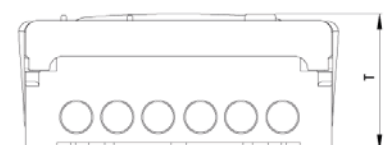
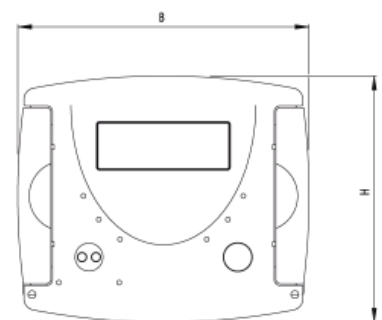

Flow sensor ETH

Single-jet flow sensor for flow rates up to q_p 2.5

The ETH is a flow sensor for flows of up to q_p 2.5 with horizontal or vertical mounting. Thanks to its compact dimensions, this heat meter flow sensor can also be used in cramped installation positions.

The strengthened bearing means a high level of measurement stability, as well as a large load range.

Characteristics in a glance

- Strengthened bearing
- High measurement stability
- Large load range
- Permanent loads of up to 120°C

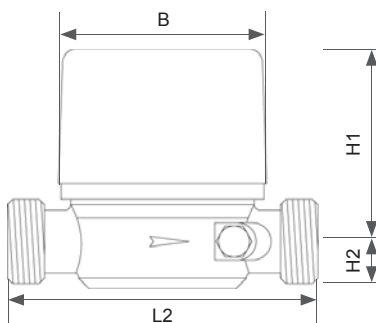

Technical data flow sensor ETH

Nominal flow	q_p	m ³ /h	0,6	1,5	2,5
Nominal diameter	DN	mm	15	15	20
		inch	½	½	¾
Length without connectors	L2	mm	110	110	130
Length with connectors	L1	mm	190	190	226
Thread meter G x B	D1	inch	¾	¾	1
Thread connector R x	D2	inch	½	½	¾
Metrological class			B	B	B
Pulse value		l/Imp	10	10	10
Maximum flow*	q_s	m ³ /h	1,2	3	5
Minimum flow	q_i	l/h	12	30	50
Maximum temperature		°C	120	120	120
Operating pressure, max.	PN	bar	16	16	16
Flow at 0,1 bar pressure loss		m ³ /h	0,4	1,1	1,7
Height	H1	mm	80	80	80
	H2	mm	20	20	20
Wide	B	mm	75	75	75
Weight		kg	0,8	0,8	1

* Short-term maximum flow; flow sensors should be designed so that a pressure loss of 0,1 bar is not exceeded at maximum flow.

Flow sensor ISF

Single-jet flow sensor for flow rates up to q_p 2.5

The flow sensor ISF is a single-jet impeller flow sensor with high-resolution, interference-free and reactionless electronic scanning using ultra-modern microcontroller technology, making it suitable for a variety of measuring activities.

Characteristics in a glance

- Can be installed in flow or return
- Vertical or horizontal mounting permitted
- Temperature range 10°C – 90°C
- Insensitive to magnetite thanks to electronic scanning
- Available in q_p 0.6 / 1.5 / 2.5 m³/hr



Technical data flow sensor ISF					
Nominal flow	q_p	m ³ /h	0,6	1,5	2,5
Maximum flow	q_s	m ³ /h	1,2	3,0	5,0
Minimum flow horizontally (optionally)	q_i	l/h	12 / 24	30 / 60	50 / 100
Minimum flow vertically (optionally)	q_i	l/h	12 / 24	30 / 60	50 / 100
Pressure loss at q_p		bar		<= 0,25	
Minimum pressure (avoiding of cavitation)		bar		0,3	
Temperature range of the heat transfer medium		°C		10 <= Θ_q <= 90	
Measurement accuracy class				3	
Output pulse value		l/Imp		according to type plate l/pulse	
Ambient conditions/influencing parameters, climatic				highest permissible ambient temperature 55°C lowest permissible ambient temperature 5°C	
Humidity class				IP 54	
Mechanical class				M1	
Electromagnetic class				E1	
Auxiliary power				lithium battery	
Battery lifetime				5 years + 1 year reserve	
Length of the connecting cable				2 m, max. 10 m	
Heat transfer medium				Water	
Pressure classes	PN/PS			16	
Installation length	L	mm	110	110	130
Connection thread			G $\frac{3}{4}$ B	G $\frac{3}{4}$ B	G1B
Height from the middle of the pipe	H	mm	ca. 45	ca. 45	ca. 49
Required minimum installation height		mm	20	20	20

Flow sensor IMF

Multi-jet flow sensor for flow rates up to q_p 10

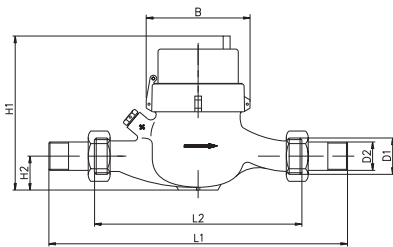

The IMF is a flow sensor for flows of 3.5m³/hr to 10m³/hr with a horizontal mounting. Its particular construction ensures high measuring accuracy and reliable measurement stability. Its connection and structural dimensions are in line with DIN ISO 4064. If desired we can supply a flange version with flange dimensions in line with DIN EN 1092.

Characteristics in a glance

- High measurement stability
- Large load range
- Permanent loads of up to 120°C
- MID type examination certificate in metrological class 2
- Can be combined with the multidata WR3 or other standard energy calculators

Technical data flow sensor IMF

Nominal flow	q_p	m ³ /h	3,5	6	6	10	6	10
Nominal diameter	DN	mm	25	25	32	40	25	40
		inch	1	1	1 ¼	1 ½	--	--
Length without connectors	L2	mm	260	260	260	300	260	300
Length with connectors	L1	mm	378	378	384	428	--	--
Thread meter G x B	D1	inch	1 ¼	1 ¼	1 ½	2	Flange	Flange
Thread connector R x	D2	inch	1	1	1 ¼	1 ½	--	--
Metrological class	optionally class 2 or 3 according to EN 1434							
Pulse value		l/Imp	10	10	10	10	10	10
Maximum flow	q_s	m ³ /h	7	12	12	20	12	20
Minimum flow	q_i	m ³ /h	0,14	0,12/0,24	0,12/0,24	0,2/0,4	0,12/0,24	0,2/0,4
Maximum temperature	°C	5°C ≤ Θ_q ≤ 120°C						
Operating pressure, max.	PN/PS	bar	16 (Threaded connection) / 25 (Flange)					
Ambient conditions/ influencing parameters	climatic	highest permissible ambient temperature 55°C						
		lowest permissible ambient temperature 5°C, humidity class IP65						
	mechanical class				M2			
	elektromagnetic class				E2			
Pressure loss at q_p		bar	≤ 0,25					
Height	H1	mm	160	160	160	174	160	174
	H2	mm	40	40	40	50	40	50
Wide	B	mm	95	95	95	110	95	110
Weight		kg	2,9	2,9	2,9	5,1	4,5	9,5

Flow sensor IMF-ST und IMF-F

Multi-jet flow sensor for flow rates up to q_p 10

The IMF-ST and IMF-F are flow sensors for flow rates of 3.5 m³/hr to 10 m³/hr. The IMF-ST type is for vertical mounting in standpipes and the IMF-F is designed for downpipes. The connection and structural dimensions of the meter are in line with DIN 19648 part 3.

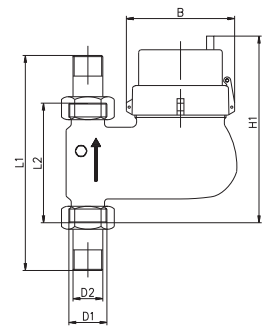

Characteristics in a glance

- For vertical mounting (standpipe: IMF-ST)
- For horizontal mounting (downpipe: IMF-F)
- Permanent loads of up to 120°C
- MID type examination certificate in metrological class 2
- Can be combined with the multidata WR3 or other standard energy calculators

Technical data flow sensor IMF-ST, IMF-F								
Nominal flow	q_p	m ³ /h	3,5	3,5	6	6	10	10
Nominal diameter	DN	mm	25	25	25	32	32	40
		inch	1	1	1	1 ¼	1 ½	1 ½
Length without connectors	L2	mm	135	150	150	150	150	200
Length with connectors	L1	mm	253	268	268	268	268	328
Thread meter G x B	D1	inch	1 ¼	1 ¼	1 ¼	1 ½	2	2
Thread connector R x	D2	inch	1	1	1 ¼	1 ¼	1 ½	1 ½
Metrological class	optionally class 2 or 3 according to EN 1434							
Pulse value		l/Imp	10	10	10	10	10	10
Maximum flow	q_s	m ³ /h	7	7	12	12	20	20
Minimum flow	q_i	m ³ /h	0,14	0,14	0,12/0,24	0,12/0,24	0,2/0,4	0,2/0,4
Maximum temperature	°C	5°C ≤ Θ_q ≤ 120°C						
Operating pressure, max.	PN/PS	bar	16					
Ambient conditions/ influencing parameters	climatic	highest permissible ambient temperature 55°C						
		lowest permissible ambient temperature 5°C, humidity class IP65						
	mechanical class		M2					
	elektromagnetic class		E2					
Pressure loss at q_p		bar	≤ 0,25					
Height	H1	mm	195	195	195	195	206 (-ST)	231 (-ST)
							197 (-F)	212 (-F)
Wide	B	mm	95	95	95	95	110	110
Weight		kg	3,1	3,1	3,1	3,1	5,5	5,5

Woltman flow sensor WPH

Flow sensor for flow rates up to q_p 250

The WPH model is designed for horizontal and vertical mounting, giving it flexible use. This meter type offers high load capacity, low head loss and a short overall length.

The WPH's structural and connection dimensions comply with DIN ISO 4064. A high-pressure version (PN 25/PN 40) and a version for head medium temperatures of over 120°C are also optionally available.

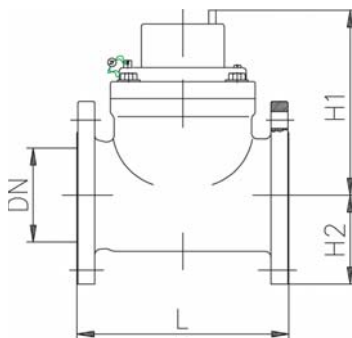

Characteristics in a glance

- Strengthened bearing
- High measurement stability
- Large load range
- Permanent loads of up to 120°C
- Can be combined with the multidata WR3 or other standard energy calculators

Technical data flow sensor WPH

Nominal flow	q_p	m ³ /h	15	25	40	60	100	150	250
Nominal diameter	DN	mm	50	65	80	100	125	150	200
Length	L	mm	200	200	225	250	250	300	350
Maximum flow*	q_s	m ³ /h	60	60	90	180	250	300	500
Minimum flow	q_i	m ³ /h	0,6	1	3,2	2	3	8	10
Pressure loss at q_p		bar	0,01	0,03	0,01	0,11	0,1	0,04	0,02
Measuring accuracy (EN 1434)	class		3	3	3	3	3	3	3
Pulse value		l/imp	100	100	100	100	1000	1000	1000
Maximum temperature		°C	120	120	120	120	120	120	120
Operating pressure, max.	PN	bar	16	16	16	16	16	16	16
Height	H1	mm	141	141	141	200	200	244	244
	H2	mm	75	82,5	94	110	125	135	163
Weight		kg	11,1	11,6	12,5	19,8	22,4	39	47
Number of screws		pcs.	4	4	8	8	8	8	8

* Short-term maximum flow; flow sensors should be designed so that a pressure loss of 0,1 bar is not exceeded at maximum flow.

Woltman flow-sensor WS

Flow sensor for flow rates up to q_p 150

The WS model is designed for mounting on horizontal pipes. This meter type is particularly suitable for sharply fluctuating flow rates in heating circuits with variable volume flow. Its particular benefit is its substantially expanded measuring range for smaller flow quantities.

Characteristics in a glance

- Strengthened bearing
- High measurement stability
- Large load range
- Permanent loads of up to 120°C
- Can be combined with the multidata WR3 or other standard energy calculators

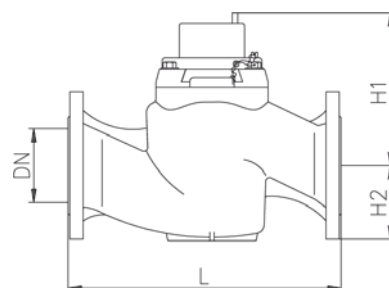

Technical data flow sensor WS							
Nominal flow	q_p	m ³ /h	15	25	40	60	150
Nominal diameter	DN	mm	50	65	80	100	150
Length	L	mm	270	300	300	360	500
Measuring accuracy (EN 1434)	class		B*H	B*H	B*H	B*H	B*H
Pulse value		l/Imp	100	100	100	100	1000
Maximum flow*	q_s	m ³ /h	50	50	110	140	350
Minimum flow	q_i	m ³ /h	0,2	0,2	0,3	0,4	2
Maximum temperature		°C	120	120	120	120	120
Operating pressure, max.	PN	bar	16	16	16	16	16
Flow at pressure loss of 0,1 bar		m ³ /h	19	21	42	70	160
Height	H1	mm	155	155	190	200	400
	H2	mm	84	97	102	113	155
Weight		kg	14,2	18	24	28	79,5
Number of screws		pcs.	4	4	8 (4)	8	8

* Short-term maximum flow; flow sensors should be designed so that a pressure loss of 0,1 bar is not exceeded at maximum flow.

Ultrasonic flow sensor sonar

Flow sensor for flow rates up to q_p 60



Particular technical or structural requirements often call for the use of an ultrasonic meter. For such cases, ZENNER offers an intelligent solution in its ultrasonic flow sensor.

The major benefit of ultrasonic flow sensors is that they have no moving parts in the volume flow and are largely resistant to deposits. They are virtually wear-free and silent in operation.

They can also bear a load of up to the twice the nominal flow, ensuring reliable measurement and a long service life.

Volume information is transmitted to the energy calculator via electronic pulses. One particular performance feature of ZENNER ultrasonic flow sensors is self-monitoring.

The measurement electronics continually check the quality of the signals transmitted by the flow sensor, meaning that any sensor pollution is immediately identified.

Technical data flow sensor sonar (version with threaded connection)

Nominal flow	q_p	m ³ /h	0,6	0,6	1,5	1,5	2,5	2,5	3,5	6	6	10	10
Nominal diameter	DN	mm	20	20	20	20	20	20	25	25	25	40	40
		inch	¾	¾	¾	¾	¾	¾	1	1	1	1 ½	1 ½
Length without connectors	L	mm	110	190	110	190	130	190	260	150	260	200	300
Thread meter G x B			1	1	1	1	1	1	1 ¼	1 ¼	1 ¼	2	2
Metrological class	class		1:50	1:50	1:50	1:50	1:50	1:50	1:100	1:100	1:100	1:100	1:100
Pulse value		l/Imp	1	1	1	1	1	1	1	1	1	1	1
Maximum flow	q_s	m ³ /h	1,2	1,2	3	3	5	5	7	12	12	20	20
Minimum flow	q_i	l/h	12	12	30	30	50	50	35	20	60	100	100
Maximum temperature		°C	130	130	130	130	130	130	130	130	130	130	130
Operating pressure, max.	PN	bar	16	16	16	16	16	16	16	16	16	16	16
Pressure loss at q_p		bar	0,17	0,17	0,16	0,16	0,14	0,14	0,06	0,15	0,15	0,12	0,12
Weight		kg	1,5	1,7	1,5	1,7	1,6	1,7	3	3	3	4	4

The flow sensor electronics can be detached in a few easy steps, meaning that the equipment is still easy to mount in cramped locations. The flow sensor sonar works in perfect combination with the multidata WR3 energy calculator with high-frequency pulse input.

Characteristics in a glance

- Six-year long-life battery
- Self-monitoring of ultrasonic system and electronics
- Flow sensor for any mounting position
- No inlet or outlet sections required
- Can bear loads of up to twice the nominal flow
- Resistant to foreign matter in the heat medium
- Virtually silent operation

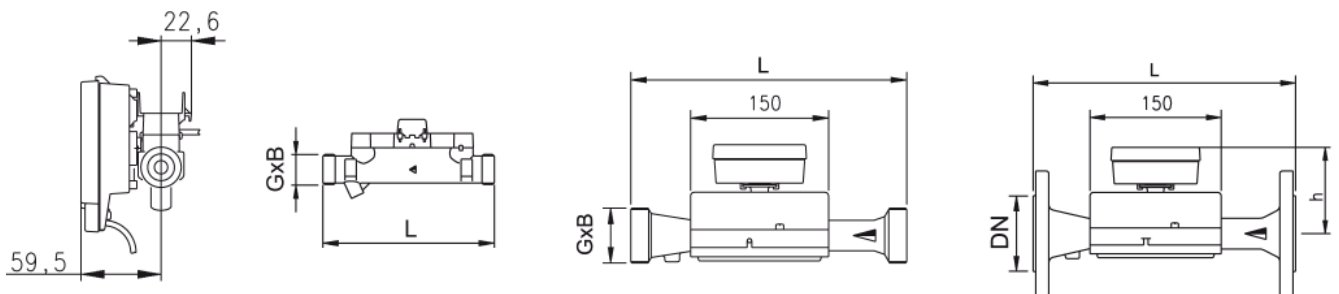

Technical data flow sensor sonar (version with flange)											
Nominal flow	q_p	m ³ /h	1,5	2,5	3,5	6	10	15	25	40	60
Nominal diameter	DN	mm	20	20	25	25	40	50	65	80	100
		inch	--	--	--	--	--	--	--	--	--
Length without connectors	L	mm	190	190	260	260	300	270	300	300	360
Thread meter G x B		Flange	Flange	Flange	Flange	Flange	Flange	Flange	Flange	Flange	Flange
Metrological class	class		1:50	1:50	1:100	1:100	1:100	1:100	1:100	1:100	1:100
Pulse value		l/Imp	1	1	1	1	1	1	10	10	10
Maximum flow	q_s	m ³ /h	3	5	7	12	20	30	50	80	120
Minimum flow	q_i	l/h	30	50	35	60	100	150	250	400	600
Maximum temperature		°C	130	130	130	130	130	130	130	130	130
Operating pressure, max.	PN	bar	25	25	25	25	25	25	25	25	25
Pressure loss at q_p		bar	0,16	0,14	0,06	0,15	0,12	0,12	0,12	0,12	0,14
Weight		kg	3	3	4	4	5,5	8	11	13	22
Number of screws		pcs.	4	4	4	4	4	4	8	8	8

Temperature sensors

Standard sensors



ZENNER's range includes platinum resistance temperature sensors of the types PT1000, PT500 and PT100 with 2-wire or 4-wire technology. They can be installed as direct sensors or in a temperature sensor sleeve. All heat meter sensors are manufactured, tested and labelled in accordance with the European Measuring Instruments Directive (MID). Cooling meter sensors comply with the PTB TW K 7.2 standard.

For new installations of heat meters up to qp 6 (DN 25) in pipelines, temperature sensors with an overall length of up to 60mm must be mounted directly in the heat medium. Mounting with a sleeve for a temperature sensor is not permissible in this case. When installing, the sensor is equipped with a direct sensor adaptor and installed in a ball cock with a temperature sensor seat. Temperature sensors with an overall length of more than 60mm are mounted using a stainless steel sleeve.



Dimensions			
d	EL	TH	Cable*
mm	mm	mm	m
5	45	-	3,0
5,2	45	-	3,0
6	105	85	3,0
6	140	120	3,0
6	230	210	3,0

*other cable length on request

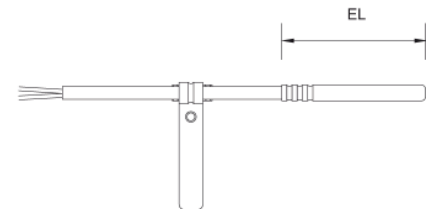

Type DS 27.5 in accordance with DIN EN 1434 (AGFW sensor)

This sensor is a special design offering an optimised response to temperature changes in the heat medium. It can only be mounted in special ball cocks or adapter pieces – sleeve installation is not permissible.

Dimensions			
d	EL	L	Cable*
mm	mm	mm	m
3,4	27,5	43	1,5

*other cable length on request

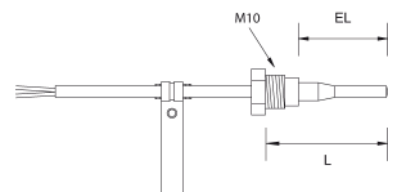

Installation accessories

Direct sensor adaptor

A direct sensor adaptor enables standard temperature sensors to be converted into direct sensors. The two plastic half shells are placed around the sensor and replicate an M10x1 thread on the exterior. This enables the sensor to be perfectly installed using for example a ball cock with a matching hole thread.



Also available in brass-version

Technical data	
Material	Heat-resistant plastic
Sensor diameter	5,0 / 5,2
Thread	M10x1

Ball valve

The ball valve with M10x1 hole is ideal for installation with direct sensors. If the ball valve is closed, the temperature sensor can be switched without any discharge of hot water. In the open position, the heat medium flows around the sensor which can react quickly and reliably to temperature changes. We supply a ball valve without a hole for shut-off purposes.



Technical data	
Material	Chromed brass
Bore	M10x1
Internal thread	1/2", 3/4", 1", 1 1/4", 1 1/2"

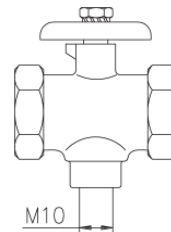

Complete ball valve installation kit with meter blank

To enable the correct pre-fitting for measuring points, complete installation kits are also available containing a ball valve with temperature sensor mount plus a meter adaptor and two ball valves with screw connections.



Stainless steel sleeve for temperature sensor

For temperature sensors with diameters of 6mm and lengths of 105mm, 140mm or 230mm, our stainless temperature sensor sleeve is available. This offers the ideal combination of stability and the lowest possible thermal resistance. These sleeves for temperature sensors are suitable for all measuring points from around q_p 10, and are installed using a suitable welding socket with a 1/2" inner thread.

Dimensions			
L	D	G	Sensor
mm	mm	inch	mm
85	6	1/2"	105
120	6	1/2"	140
210	6	1/2"	230

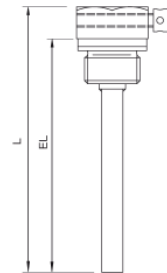

Connection interface / manifold body (EAS)

The connection interface forms the basis of the zelsius® C5 CMF measuring capsule compact heat meter. It only requires positioning upon initial installation, and then remains within the heating system. This process makes heat meters easier to replace and helps to save on exchange costs.

Dimensions		
q_p	BL	G x B
m ³ /h	mm	inch
0,6 / 1,5	110	3/4" / 18 mm soldering
0,6 / 1,5	130	1" / 22 mm soldering
2,5	130	1" / 22 mm soldering
1,5 / 2,5	105	1"

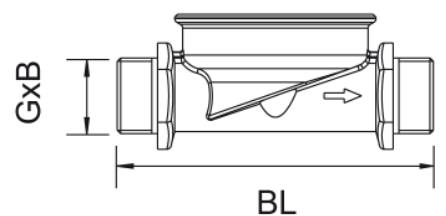

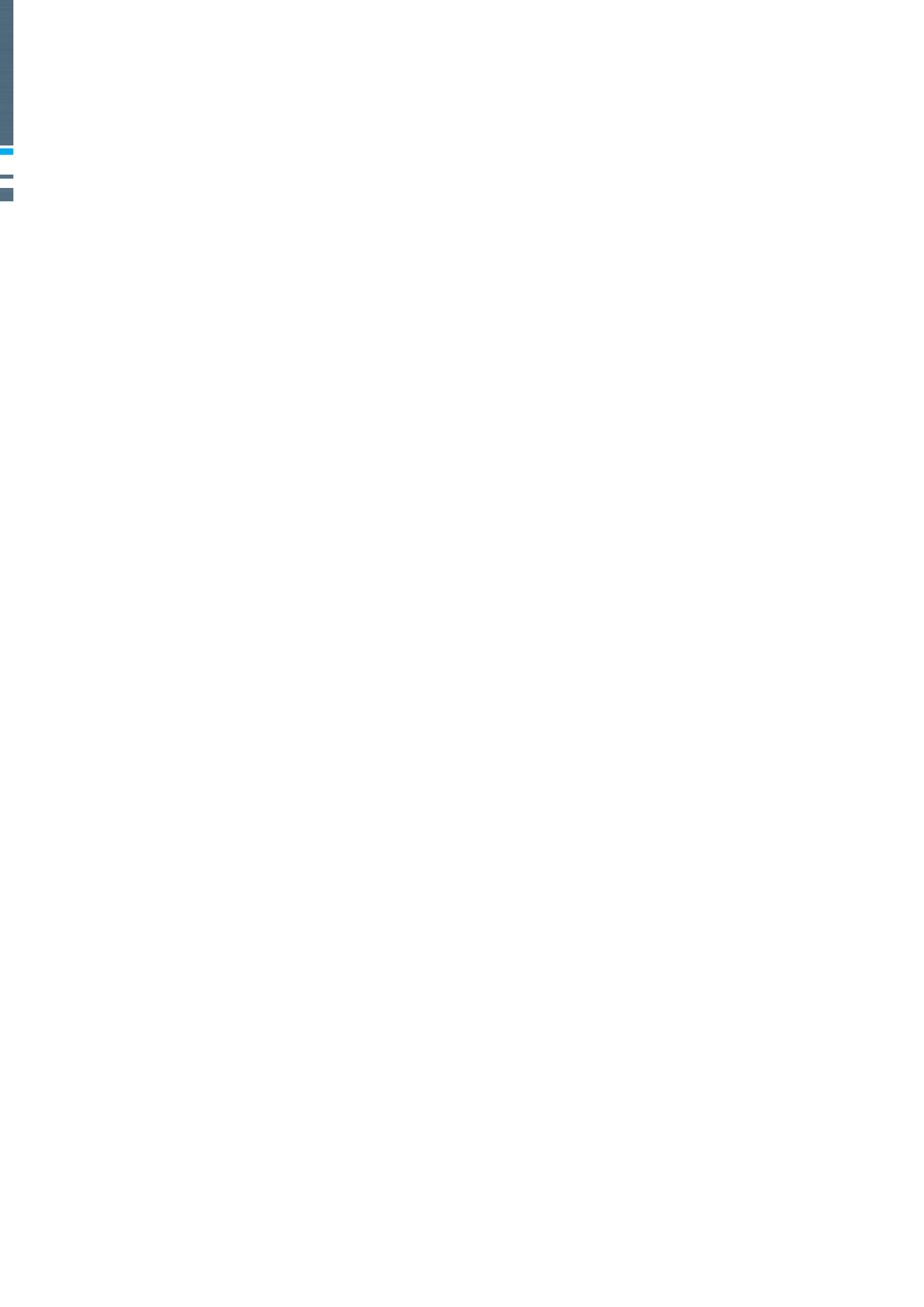

ZENNER International GmbH & Co. KG

Römerstadt 6

66121 Saarbrücken

Telefon +49 681 99 676 - 30

Telefax +49 681 99 676 - 3100

E-Mail info@zenner.com

Internet www.zenner.com